

SZ303D - SZ30D0

VZ : 3.3 - 200 Volts

PD : 1.5 Watts

Features

- Complete Voltage Range 3.3 to 200 Volts
- High peak reverse power dissipation
- High reliability
- Low leakage current
- RoHS compliant package

Mechanical Data

- Case : SMA(DO-214AC) Molded plastic
- Epoxy : UL94V-0 rate flame retardant
- Lead : Lead Formed for Surface Mount
- Polarity : Color band denotes cathode end
- Mounting position : Any
- Weight : 0.065 gram

Packing & Order Information

5,000/Reel

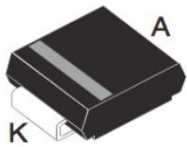

**RoHS
COMPLIANT**

SMA (DO-214AC)

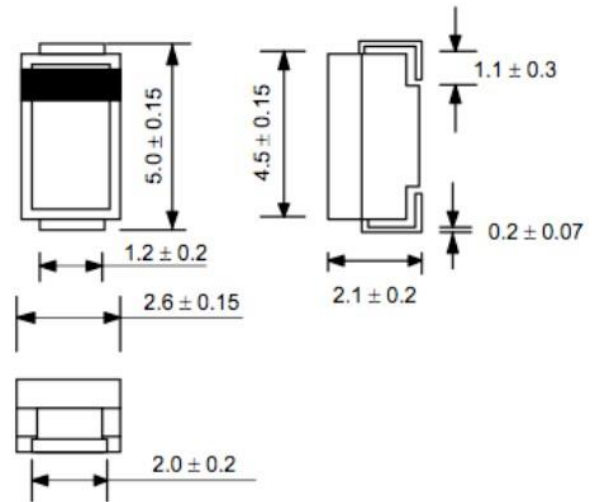

Dimensions in millimeters

Graphic symbol

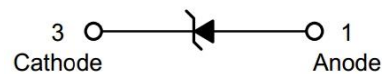

MAXIMUM RATINGS AND ELECTRICAL CHARACTERISTICS

Rating at 25 °C ambient temperature unless otherwise specified.

Symbol	Parameter	Value	Unit
PD	DC Power Dissipation at $T_L = 75\text{ °C}$ (Note 1)	1.5	W
VF	Maximum Forward Voltage at $I_F = 200\text{ mA}$	1.5	V
TJ	Junction Temperature Range	- 55 to + 150	°C
TSTG	Storage Temperature Range	- 55 to + 150	°C

Note : T_L = Lead temperature at 5.0 mm2 (0.013 mm thick) copper land areas.

Fig. 1 POWER TEMPERATURE DERATING CURVE

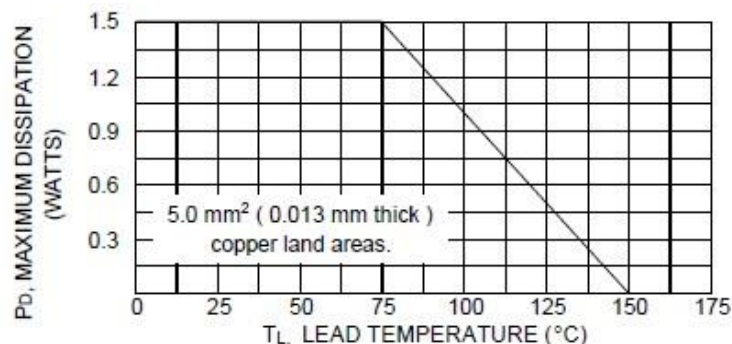

SZ303D - SZ30D0

VZ : 3.3 - 200 Volts

PD : 1.5 Watts

ELECTRICAL CHARACTERISTICS (Rating at 25°C ambient temperature unless otherwise specified)

Type	Nominal Zener Voltage		Maximum Zener Impedance			Maximum Reverse Leakage Current		Maximum DC Zener Current
	VZ @ IZT	IZT	ZZT @ IZT	ZZK @ IZK	IZK	IR @ VR		IZM
	(V)	(mA)	(Ω)	(Ω)	(mA)	(μ A)	(V)	(mA)
SZ303D	3.3	113.6	10	500	1.0	100	1.0	454
SZ303G	3.6	104.2	9.0	500	1.0	75	1.0	416
SZ303J	3.9	96.1	7.5	500	1.0	50	1.0	384
SZ304D	4.3	87.2	6.0	500	1.0	50	1.0	348
SZ304H	4.7	79.8	5.0	500	1.0	50	1.5	319
SZ305B	5.1	73.5	4.0	350	1.0	50	2.0	294
SZ305G	5.6	66.9	2.0	250	1.0	50	3.0	267
SZ306C	6.2	60.5	2.0	200	1.0	50	4.0	241
SZ306I	6.8	55.1	2.5	200	1.0	50	5.2	220
SZ307F	7.5	50.0	3.0	400	0.5	50	6.0	200
SZ308C	8.2	45.7	3.5	400	0.5	50	6.5	182
SZ309B	9.1	41.2	4.0	500	0.5	50	7.0	164
SZ3010	10	37.5	4.5	500	0.25	50	8.0	150
SZ3011	11	34.1	5.5	550	0.25	50	8.4	136
SZ3012	12	31.2	6.5	550	0.25	1.0	9.1	125
SZ3013	13	28.8	7.0	550	0.25	1.0	9.9	115
SZ3015	15	25.0	9.0	600	0.25	1.0	11.4	100
SZ3016	16	23.4	10	600	0.25	1.0	12.2	93
SZ3018	18	20.8	12	650	0.25	1.0	13.7	83
SZ3020	20	18.7	14	650	0.25	1.0	15.2	75
SZ3022	22	17.0	17.5	650	0.25	1.0	16.7	68
SZ3024	24	15.6	19	700	0.25	1.0	18.2	62
SZ3027	27	13.9	23	700	0.25	1.0	20.6	55
SZ3030	30	12.5	26	750	0.25	1.0	22.8	50
SZ3033	33	11.4	33	800	0.25	1.0	25.1	45
SZ3036	36	10.4	38	850	0.25	1.0	27.4	41
SZ3039	39	9.6	45	900	0.25	1.0	29.7	38
SZ3043	43	8.7	53	950	0.25	1.0	32.7	34
SZ3047	47	8.0	67	1000	0.25	1.0	35.8	31
SZ3051	51	7.3	70	1100	0.25	1.0	38.8	29
SZ3056	56	6.7	86	1300	0.25	1.0	24.6	26

SZ303D - SZ30D0

VZ : 3.3 - 200 Volts

PD : 1.5 Watts

ELECTRICAL CHARACTERISTICS (Rating at 25°C ambient temperature unless otherwise specified)								
Type	Nominal Zener Voltage		Maximum Zener Impedance			Maximum Reverse Leakage Current		Maximum DC Zener Current
	VZ @ IZT	IZT	ZZT @ IZT	ZZK @ IZK	IZK	IR @ VR	IZM	VZ @ IZT
	(V)	(mA)	(Ω)	(Ω)		(V)	(mA)	(Ω)
SZ3062	62	6.0	100	1500	0.25	1.0	47.1	24
SZ3068	68	5.5	120	1700	0.25	1.0	51.7	22
SZ3075	75	5.0	140	2000	0.25	1.0	56.0	20
SZ3082	82	4.6	160	2500	0.25	1.0	62.2	18
SZ3091	91	4.1	200	3000	0.25	1.0	69.2	16
SZ30B0	100	3.7	250	3100	0.25	1.0	76.0	15
SZ30B1	110	3.4	300	4000	0.25	1.0	83.6	13
SZ30B2	120	3.1	380	4500	0.25	1.0	91.2	12
SZ30B3	130	2.9	450	5000	0.25	1.0	98.8	11
SZ30B5	150	2.5	600	6000	0.25	1.0	114.0	10
SZ30B6	160	2.3	700	6500	0.25	1.0	121.6	9.0
SZ30B8	180	2.1	900	7000	0.25	1.0	136.8	8.0
SZ30D0	200	1.9	1200	8000	0.25	1.0	152.0	70

Note :

(1) The type number listed have a standard tolerance on the nominal zener voltage of $\pm 10\%$, altered the fourth number of type from " 0 " for $\pm 10\%$ tolerance to be " 5 " for $\pm 5.0\%$ tolerance.

SZ303D - SZ30D0

VZ : 3.3 - 200 Volts

PD : 1.5 Watts

■ RATING AND CHARACTERISTIC CURVES (P6SMB SERIES)

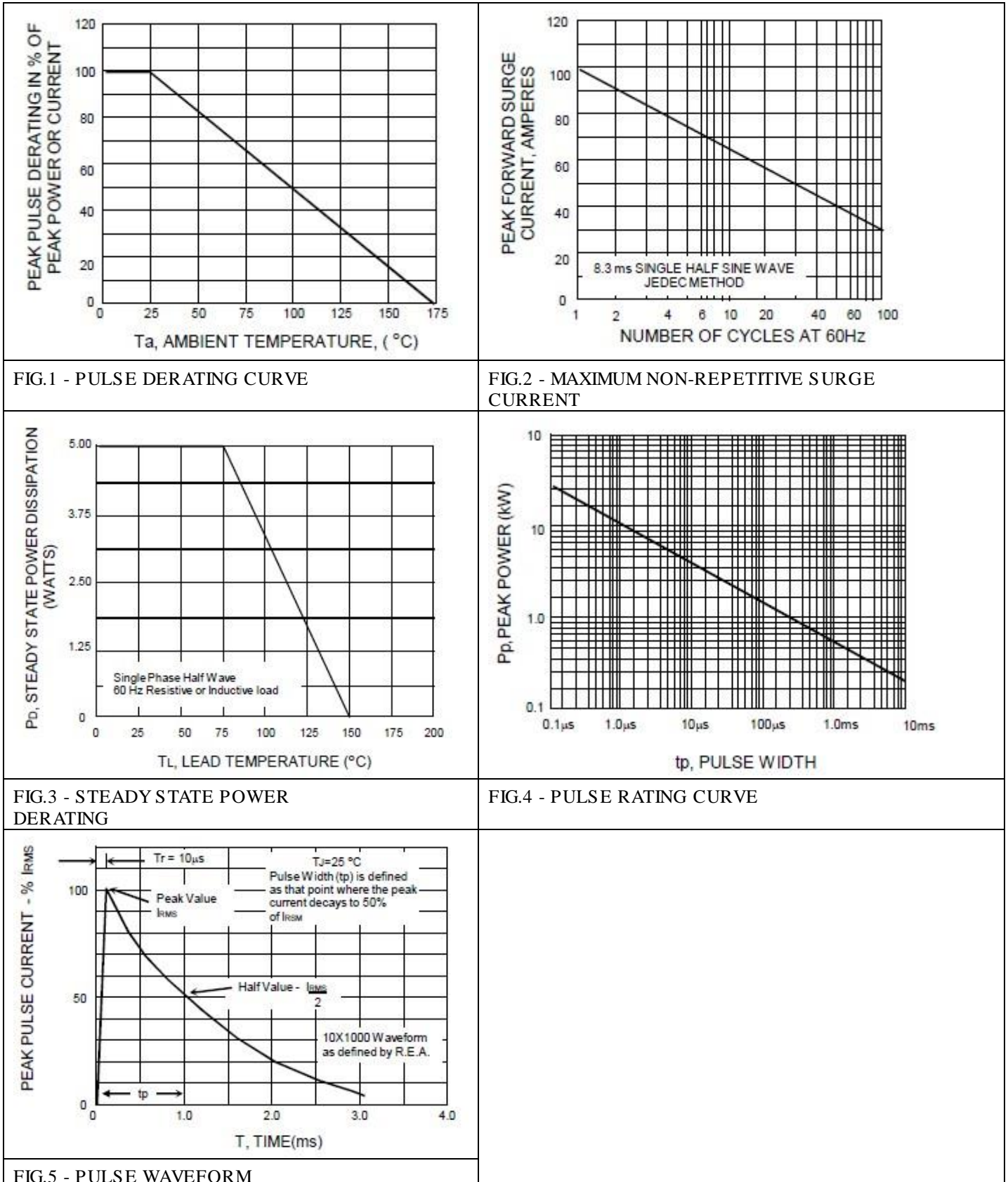

SZ303D - SZ30D0

VZ : 3.3 - 200 Volts

PD : 1.5 Watts

Disclaimer

ALL PRODUCT, PRODUCT SPECIFICATIONS AND DATA ARE SUBJECT TO CHANGE

WITHOUT NOTICE TO IMPROVE RELIABILITY, FUNCTION OR DESIGN OR OTHERWISE.

Bruckewell Technology Inc., its affiliates, agents, and employees, and all persons acting on its or their behalf (collectively, "Bruckewell"), disclaim any and all liability for any errors, inaccuracies or incompleteness contained in any datasheet or in any other disclosure relating to any product.

Bruckewell makes no warranty, representation or guarantee regarding the suitability of the products for any particular purpose or the continuing production of any product. To the maximum extent permitted by applicable law, Bruckewell disclaims

- (i) Any and all liability arising out of the application or use of any product.
- (ii) Any and all liability, including without limitation special, consequential or incidental damages.
- (iii) Any and all implied warranties, including warranties of fitness for particular purpose, non-infringement and merchantability.

Statements regarding the suitability of products for certain types of applications are based on Bruckewell's knowledge of typical requirements that are often placed on Bruckewell products in generic applications.

Such statements are not binding statements about the suitability of products for a particular application. It is the customer's responsibility to validate that a particular product with the properties described in the product specification is suitable for use in a particular application. Parameters provided in datasheets and/or specifications may vary in different applications and performance may vary over time.

Product specifications do not expand or otherwise modify Bruckewell's terms and conditions of purchase, including but not limited to the warranty expressed therein.