

# MSU4N40

## 400V N-Channel MOSFET

### Description

The MSU4N40 is a N-channel enhancement-mode MOSFET, providing the designer with the best combination of fast switching, ruggedized device design, low on-resistance and cost effectiveness. The TO-251 package is universally preferred for all commercial-industrial applications

### Features

- Originative New Design
- 100% EAS Test
- Rugged Gate Oxide Technology
- Extremely Low Intrinsic Capacitances
- Remarkable Switching Characteristics
- Unequalled Gate Charge : 25 nC (Typ.)
- Extended Safe Operating Area
- Lower RDS(ON) : 0.78  $\Omega$  (Typ.) @VGS=10V
- RoHS compliant package

### Packing & Order Information

80/Tube ; 4,000/Box

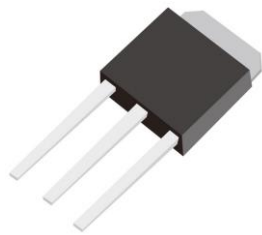

**RoHS  
COMPLIANT**

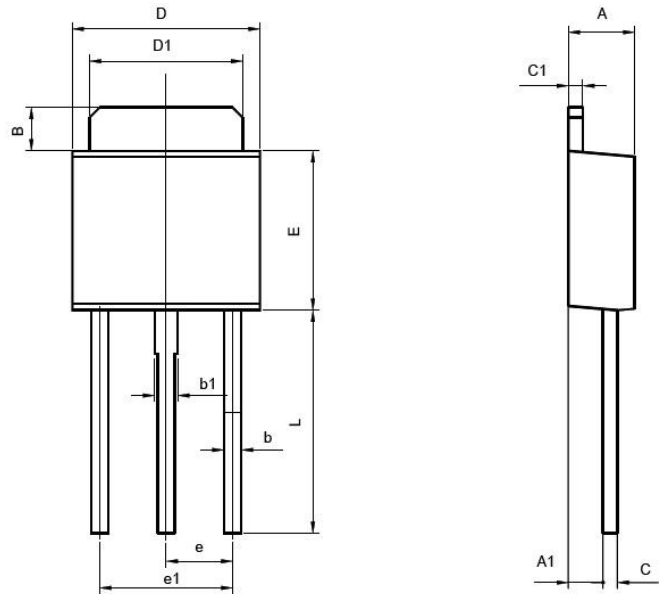

Symbol	Dimensions in Millimeters		Dimensions in Inches	
	min	max	min	max
A	2.15	2.45	0.85	0.96
A1	1.00	1.40	0.39	0.55
B	1.25	1.75	0.49	0.69
b	0.45	0.75	0.18	0.3
b1	0.65	0.95	0.26	0.37
C	0.38	0.64	0.15	0.25
C1	0.38	0.64	0.15	0.25
D	6.30	6.70	2.48	2.64
D1	5.10	5.50	2.01	2.17
E	5.30	5.70	2.09	2.24
e	2.3 (typ.)		0.91 (typ.)	
e1	4.4	4.8	1.73	1.89
L	7.4	8.0	2.91	3.15

Graphic symbol

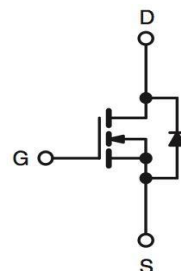

## MSU4N40

### 400V N-Channel MOSFET

#### MAXIMUM RATINGS AND ELECTRICAL CHARACTERISTICS

##### Absolute Maximum Ratings (Tc=25°C unless otherwise noted)

Symbol	Parameter	Value	Unit
V <sub>DSS</sub>	Drain-Source Voltage	400	V
V <sub>GS</sub>	Gate-Source Voltage	±30	V
I <sub>D</sub>	Drain Current -Continuous (TC=25°C)	4.5	A
	Drain Current -Continuous (TC=100°C)	3.0	A
I <sub>DM</sub>	Drain Current Pulsed	22	A
E <sub>AS</sub>	Single Pulsed Avalanche Energy	270	mJ
E <sub>AR</sub>	Repetitive Avalanche Energy	7.3	mJ
dV/dt	Peak Diode Recovery dV/dt	4.5	V/ns
P <sub>D</sub>	Power Dissipation (TC = 25 °C)	25	W
	- Derate above 25°C	0.38	W/°C
T <sub>J</sub> ,T <sub>STG</sub>	Operating and Storage Temperature Range	-55 to +150	°C
T <sub>L</sub>	Maximum lead temperature for soldering purposes, 1/8" from case for 5 seconds	300	°C

- Drain current limited by maximum junction temperature

##### Thermal Resistance Characteristics

Symbol	Parameter	Max.	Units
R <sub>θJC</sub>	Junction-to-Case	1.72	°C/W
R <sub>θJA</sub>	Junction-to-Ambient	83.3	

##### On Characteristics

Symbol	Test Conditions	Min	Typ.	Max.	Units
V <sub>GS</sub>	V <sub>DS</sub> = V <sub>GS</sub> , I <sub>D</sub> = 250μA	2.0	--	4.0	V
*R <sub>DS(ON)</sub>	V <sub>GS</sub> = 10 V , I <sub>D</sub> = 1 A	--	0.78	0.9	Ω

##### Static Characteristics

Symbol	Test Conditions	Min	Typ.	Max.	Units
BV <sub>DSS</sub>	V <sub>GS</sub> = 0 V , I <sub>D</sub> =250μA	400	--	--	V
ΔBV <sub>DSS</sub> / ΔT <sub>J</sub>	I <sub>D</sub> = 250μA, Referenced to 25°C	--	0.54	--	V/°C
I <sub>DSS</sub>	V <sub>DS</sub> = 400 V , V <sub>GS</sub> = 0 V	--	--	1	μA
	V <sub>DS</sub> = 320 V , T <sub>C</sub> = 125°C	--	--	10	
I <sub>GSSF</sub>	V <sub>GS</sub> = 30 V , V <sub>DS</sub> = 0 V	--	--	100	nA
I <sub>GSSR</sub>	V <sub>GS</sub> = -30 V , V <sub>DS</sub> = 0 V	--	--	-100	nA

## MSU4N40

### 400V N-Channel MOSFET

Dynamic Characteristics					
Symbol	Test Conditions	Min	Typ.	Max.	Units
$t_{d(on)}$	$V_{DS} = 200\text{ V}, I_D = 4.5\text{ A},$ $R_G = 25\ \Omega$	--	15	35	ns
$t_r$		--	65	140	ns
$t_{d(off)}$		--	23	55	ns
$t_f$		--	40	85	ns
$Q_g$	$V_{DS} = 320\text{ V}, I_D = 4.5\text{ A},$ $V_{GS} = 10\text{ V}$	--	16	20	nC
$Q_{gs}$		--	2.3	--	nC
$Q_{gd}$		--	8.5	--	nC
$C_{ISS}$	$V_{DS} = 25\text{ V}, V_{GS} = 0\text{ V},$ $F = 1.0\text{ MHz}$	--	480	625	pF
$C_{OSS}$		--	80	105	pF
$C_{RSS}$		--	15	20	pF

Source-Drain Diode Maximum Ratings and Characteristics						
Symbol	Parameter	Test Conditions	Min	Typ.	Max.	Units
$I_S$			--	--	4.5	A
$I_{SM}$			--	--	18	
$V_{SD}$	$I_S = 4.5\text{ A}, V_{GS} = 0\text{ V}$		--	--	1.4	V
$t_{rr}$	$I_S = 4.5\text{ A}, V_{GS} = 0\text{ V}$		--	230	--	ns
$Q_{rr}$	$diF/dt = 100\text{ A}/\mu\text{s}$		--	1.7	--	$\mu\text{C}$

Notes ;

1. Repetitive Rating: Pulse width limited by maximum junction temperature
2.  $I_{AS}=4.5\text{ A}, V_{DD}=50\text{ V}, R_G=25\ \Omega, \text{ Starting } T_J=25^\circ\text{C}$
3.  $I_{SD}\leq 4.5\text{ A}, di/dt\leq 300\text{ A}/\mu\text{ s}, V_{DD}\leq BV_{DSS}, \text{ Starting } T_J=25^\circ\text{C}$
4. Pulse Test: Pulse Width  $\leq 300\ \mu\text{ s}, \text{ Duty Cycle } \leq 2\%$
5. Essentially Independent of Operating Temperature

## MS U4N40

### 400V N-Channel MOSFET

#### Characteristics Curve

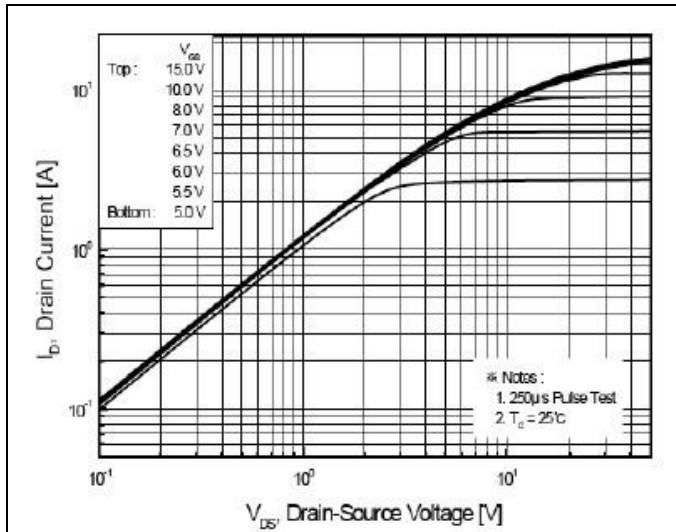

FIG.1-ON REGION CHARACTERISTICS

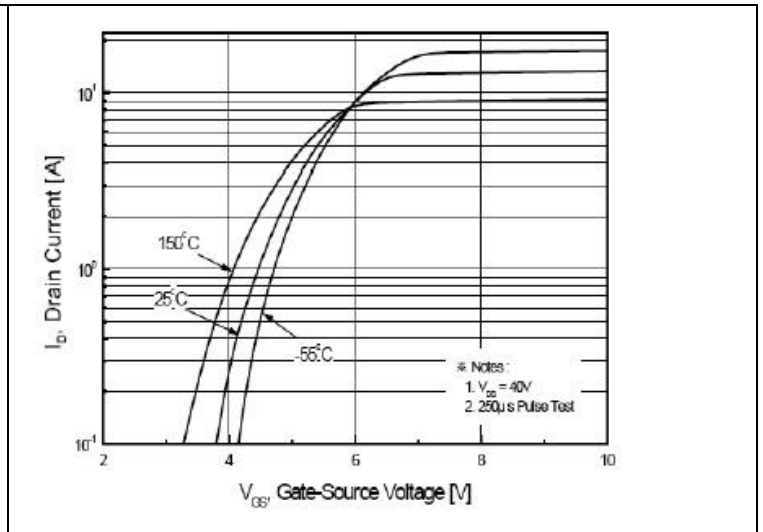

FIG.2-TRANSFER CHARACTERISTICS

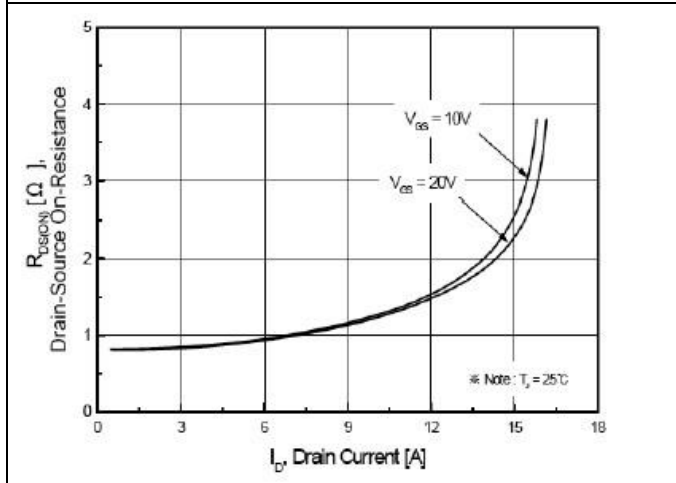

FIG.3-ON RESISTANCE VARIATION VS DRAIN CURRENT AND GATE VOLTAGE

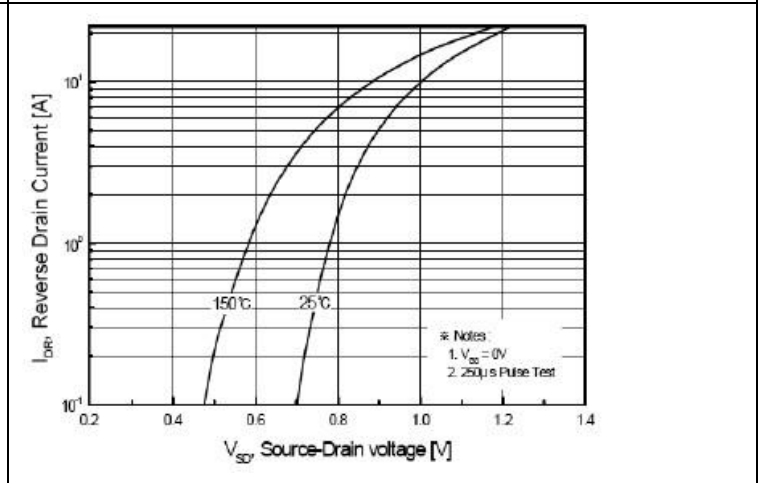

FIG.4-BODY DIODE FORWARD VOLTAGE VARIATION WITH SOURCE CURRENT AND TEMPERATURE

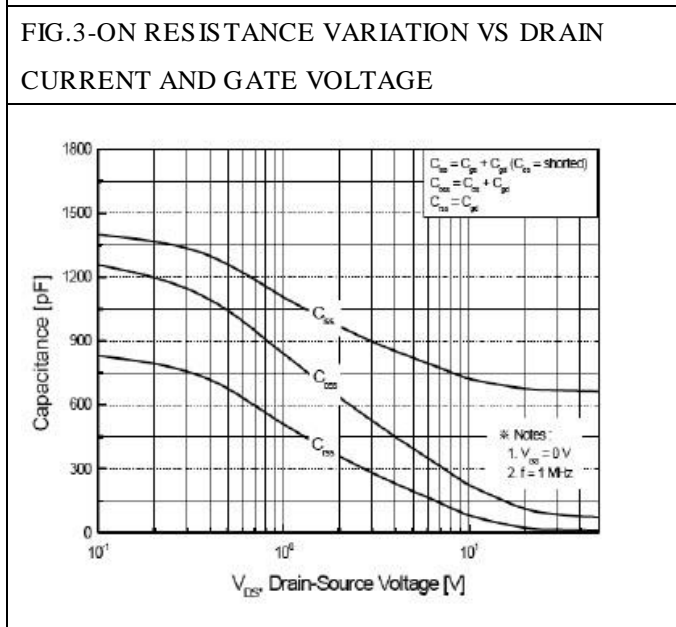

FIG.5-CAPACITANCE CHARACTERISTICS

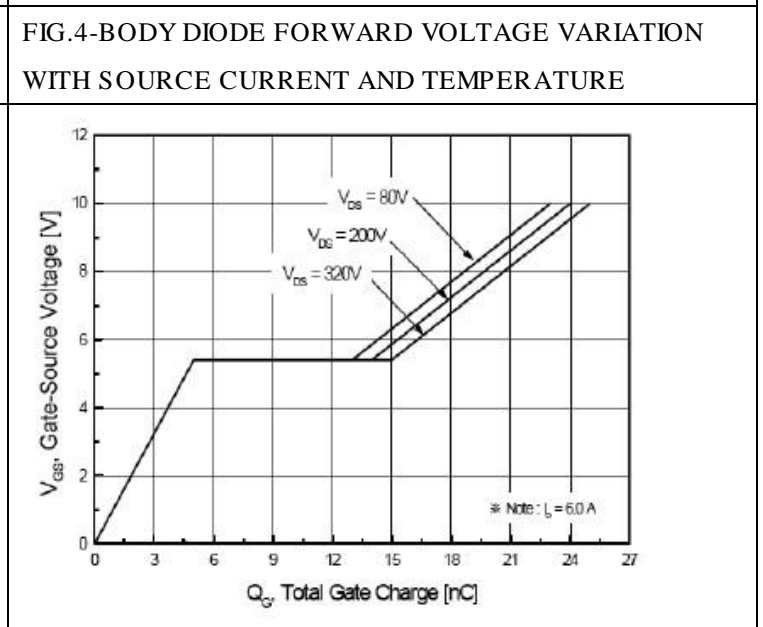

FIG.6-GATE CHARGE CHARACTERISTICS

## MSU4N40

### 400V N-Channel MOSFET

#### Characteristics Curve

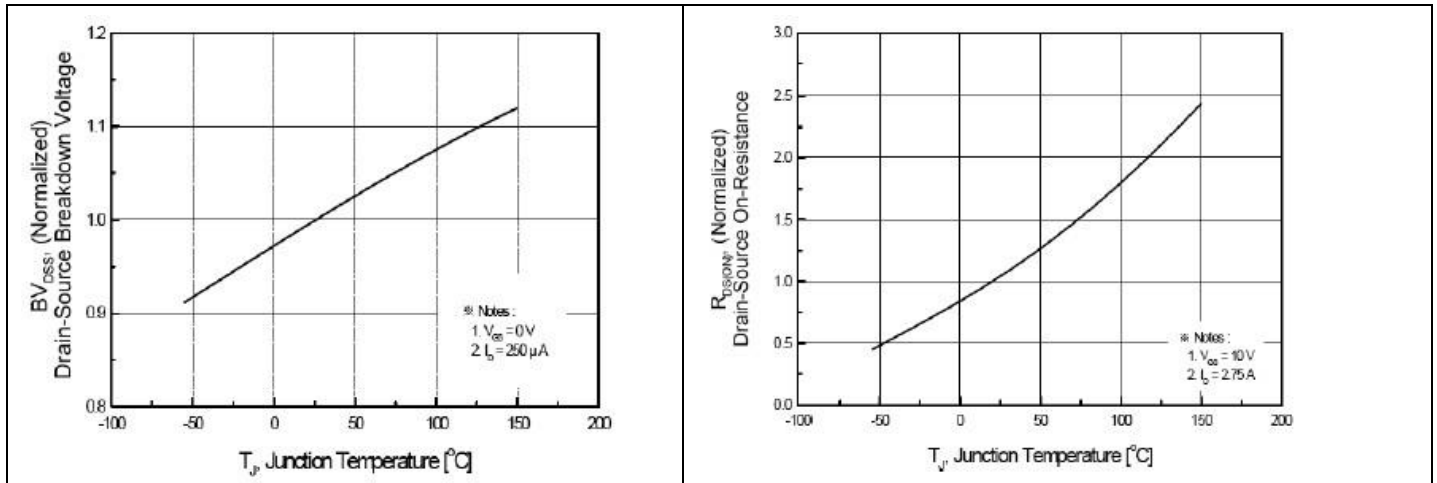

FIG. 7-BREAKDOWN VOLTAGE VARIATION VS TEMPERATURE

FIG. 8-ON-RESISTANCE VARIATION VS TEMPERATURE

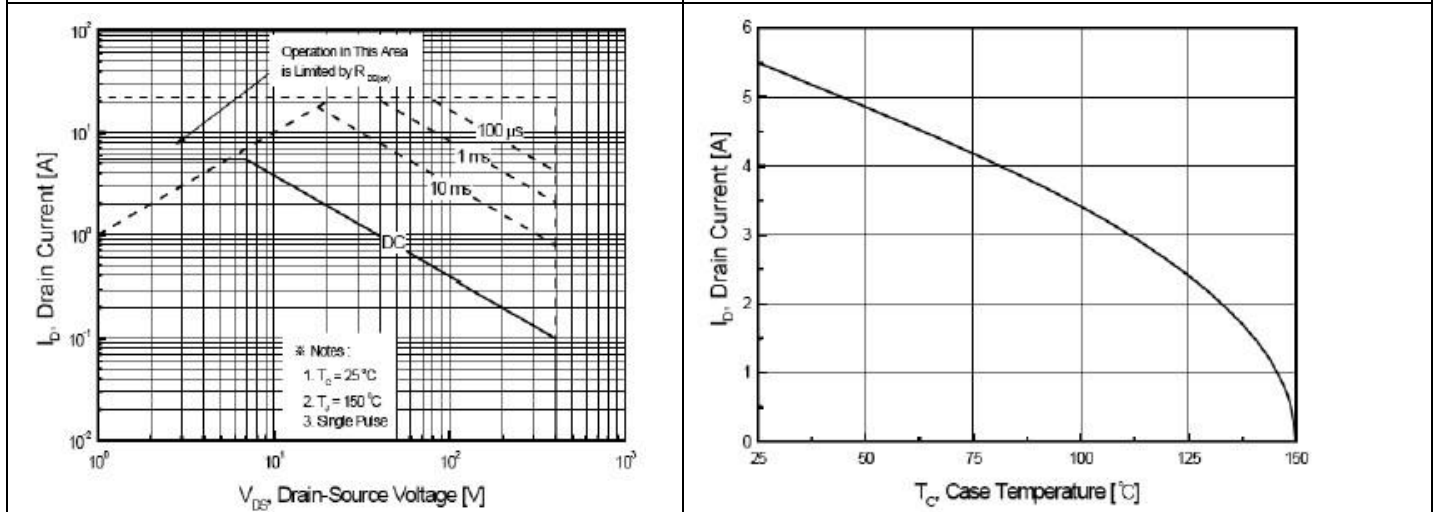

FIG. 9-MAXIMUM SAFE OPERATING AREA

FIG. 10-MAXIMUM DRAIN CURRENT VS CASE TEMPERATURE

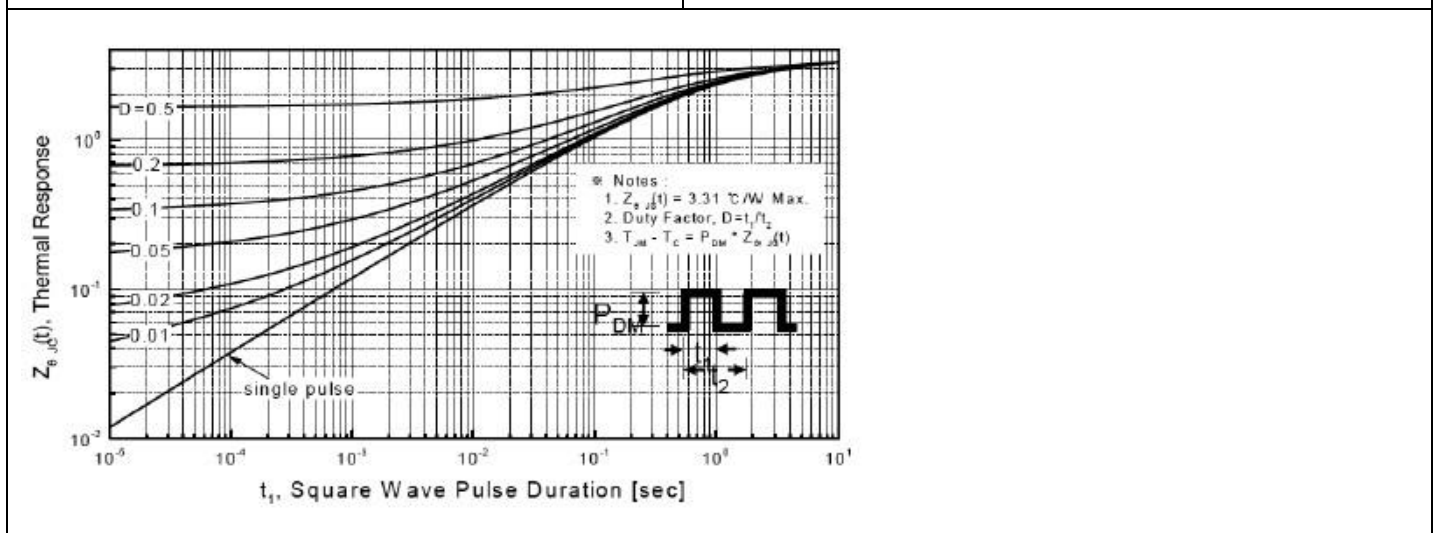

FIG. 11-TRANSIENT THERMAL RESPONSE CURVE

## MSU4N40

### 400V N-Channel MOSFET

#### ■ Characteristics Test Circuit & Waveform

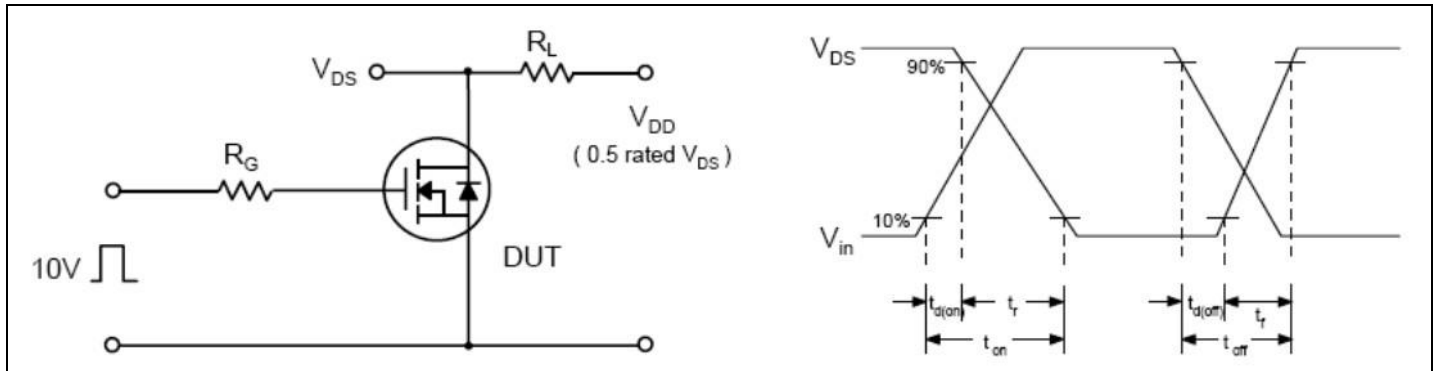

FIG.12-RESISTIVE SWITCHING TEST CIRCUIT & WAVEFORMS

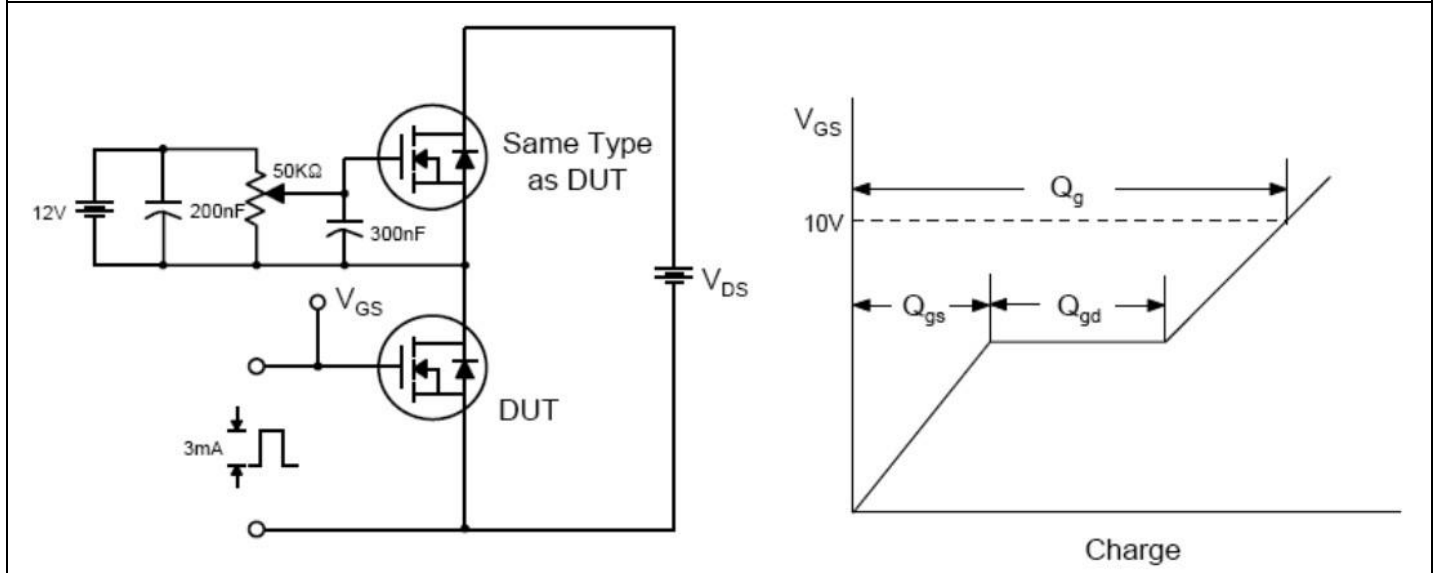

FIG.13-GATE CHARGE TEST CIRCUIT & WAVEFORM

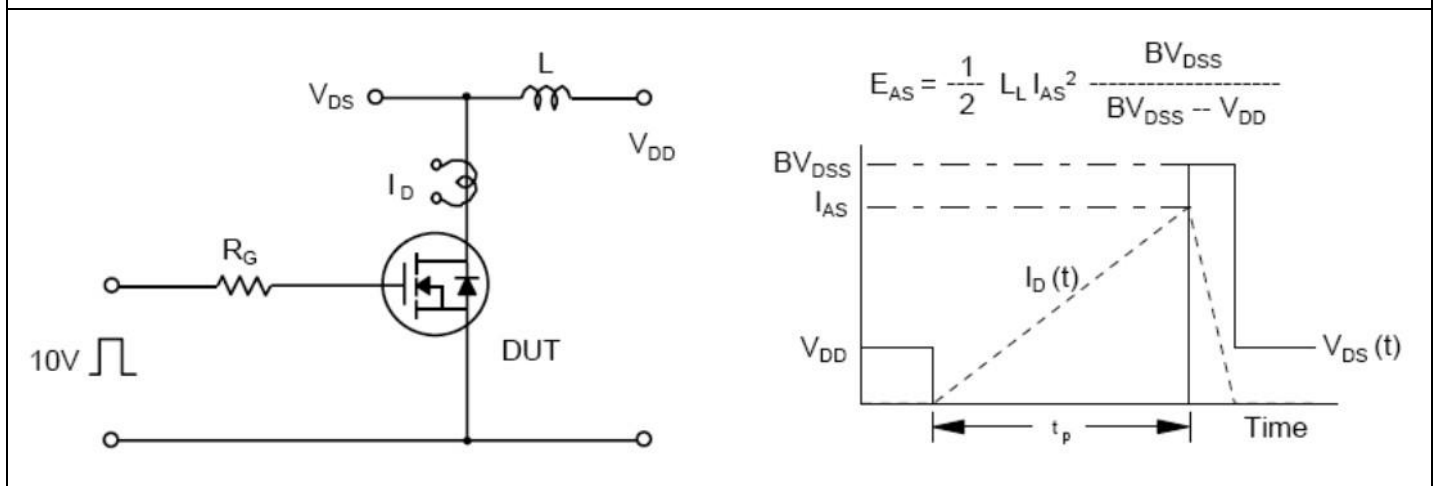

FIG.14-UNCLAMPED LINDUCTIVE SWITCHING TEST CIRCUIT & WAVEFORMS



## MSU4N40

400V N-Channel MOSFET

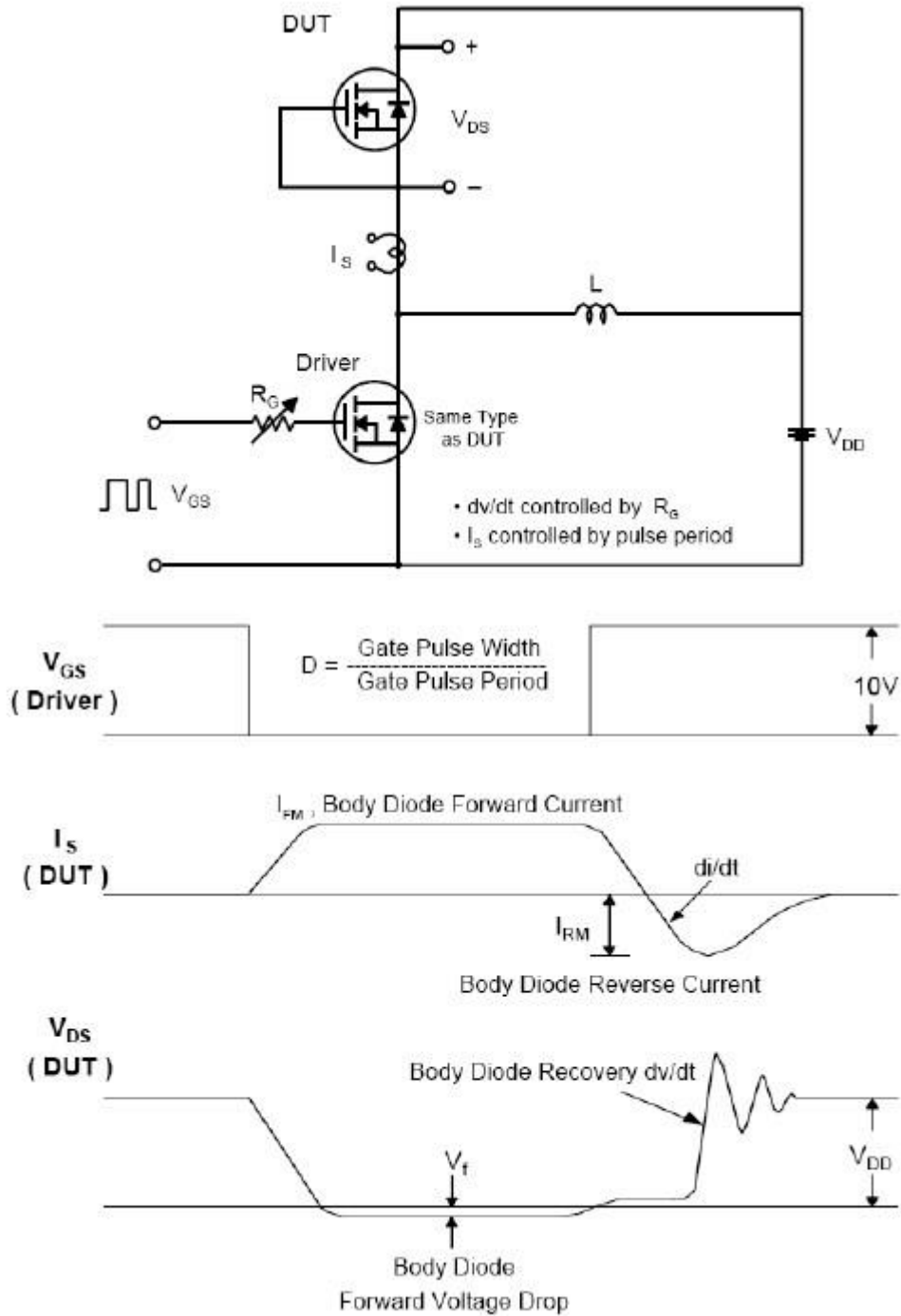

Fig 15. Peak Diode Recovery  $dv/dt$  Test Circuit & Waveforms

## MSU4N40

### 400V N-Channel MOSFET

#### Disclaimer

ALL PRODUCT, PRODUCT SPECIFICATIONS AND DATA ARE SUBJECT TO CHANGE

WITHOUT NOTICE TO IMPROVE RELIABILITY, FUNCTION OR DESIGN OR OTHERWISE.

Bruckewell Technology Inc., its affiliates, agents, and employees, and all persons acting on its or their behalf (collectively, "Bruckewell"), disclaim any and all liability for any errors, inaccuracies or incompleteness contained in any datasheet or in any other disclosure relating to any product.

Bruckewell makes no warranty, representation or guarantee regarding the suitability of the products for any particular purpose or the continuing production of any product. To the maximum extent permitted by applicable law, Bruckewell disclaims

- (i) Any and all liability arising out of the application or use of any product.
- (ii) Any and all liability, including without limitation special, consequential or incidental damages.
- (iii) Any and all implied warranties, including warranties of fitness for particular purpose, non-infringement and merchantability.

Statements regarding the suitability of products for certain types of applications are based on Bruckewell's knowledge of typical requirements that are often placed on Bruckewell products in generic applications.

Such statements are not binding statements about the suitability of products for a particular application. It is the customer's responsibility to validate that a particular product with the properties described in the product specification is suitable for use in a particular application. Parameters provided in datasheets and/or specifications may vary in different applications and performance may vary over time.

Product specifications do not expand or otherwise modify Bruckewell's terms and conditions of purchase, including but not limited to the warranty expressed therein.